



Applications

- Studio-Transmitter-Link
- MPX Transport
- Monitoring Receiver

Features

- Up to 16 AES3 or 8 analog outputs in 1RU
- RAVENNA/AES67/Livewire+/ST2110-30/-31 outputs
- Quad 10/100/1000 Ethernet interfaces with dynamic role assignment
- Highly energy efficient
- Remote control using REST API, SNMPv2c, Ember+, NMOS IS-04/IS-05
- State-of-the-art security

The next-generation audio satellite receiver.

Building on the success of the Q8V Codec System software platform, the Q9X-R is the new DVB-S2 satellite receiver from Qbit.

Decoding up to 16 channels in 1RU, it sets new standards in density. Up to 8 channels may be output using analog audio, 16 channels may be output either to AES/EBU or via RAVENNA/AES67.

Optionally, the device can output the received transport stream via IP or ASI.

The device may also receive a transport stream or elementary stream via IP as well as internet radio streams for redundancy. SRT and RIST are supported to assist in error-resilient transport of streams over the internet.

Additionally, a file backup may be purchased as an option that allows to use a locally stored file as a failsafe.

As all other devices using the Q9X platform, it offers 4 freely assignable network interfaces to adapt to every application.

State-of-the-art encoding algorithms such as xHE-AAC® and well-established algorithms such as MPEG-1 Layer II/III and AAC are supported.

With an optional license, the device may be used for MPX transport, either uncompressed or using the MicroMPX codec, with data rates as low as 320 kbps for a full MPX signal.

The system has a flexible licensing model that allows field upgrading of channel counts and options as all devices are always delivered with a full hardware configuration.

Example Application: Studio-to-Transmitter Link

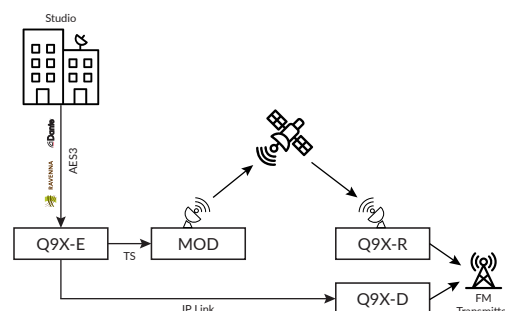

In combination with a Q9X-E IP Audio Encoder, one or multiple Q9X-R DVB-S2 Satellite Receivers or Q9X-D IP Audio Decoders, may be used for a studio-to-transmitter link over IP or via satellite.

An audio signal as well as a full MPX signal may be transported, with latter optionally using the MicroMPX codec for bandwidth-efficient transport.

Q9X-R DVB-S2 Satellite Receiver

Specifications



Satellite Tuner

Input Frequency	950 MHz to 2150 MHz
Input Signal Level	-65 dBm to -25 dBm
Supported Symbol Rates	<ul style="list-style-type: none"> ● 1 MSps to 45 MSps ○ 100 kSps to 45 MSps (VLSR Tuner)
Supported Standards	DVB-S, DVB-S2 (according to ETSI EN 300 421, ETSI EN 302 307-1/-2)
Modulation	QPSK, 8PSK, 16APSK, 32APSK
LNB Control	<ul style="list-style-type: none"> ● Universal LNB: 0V, 13V, 18V ● DiSEqC 1.x

Input Protocols: IP

MPEG-2 Transport Stream (according to ISO 13818-1)	<ul style="list-style-type: none"> ● SRT, RIST, RTP, Plain UDP ● Forward Error Correction (according to Pro-MPEG Code of Practice #3, release 2) ● Unicast, Multicast (IGMPv2/v3) ● Service Information (according to ETSI EN 300 468)
Elementary Stream (according to RFC3550, RFC3551, RFC3016, RFC3640)	<ul style="list-style-type: none"> ● SRT, RIST, RTP, Plain UDP ● Unicast, Multicast (IGMPv2/v3)
Internet Radio Streaming	<ul style="list-style-type: none"> ○ Icecast2/SHOUTcast ○ HLS ○ MPEG-DASH

Baseband Audio Output

Digital	<ul style="list-style-type: none"> ● 8x AES/EBU, XLR (IEC 958), shared with analog outputs 1-4 ● 4x AES/EBU, on 1x Sub-D 25 (TASCAM pin assignment) ○ 4x AES/EBU, on 1x Sub-D 25 (TASCAM pin assignment), shared with analog outputs 5-8
Analog	<ul style="list-style-type: none"> ● 4x Stereo Channels, on 8x XLR, shared with digital outputs 1-8 ○ 4x Stereo Channels, on 1x Sub-D 25 (TASCAM pin assignment), shared with digital outputs 13-16
Performance (Analog)	<ul style="list-style-type: none"> ● 24-bit high quality D/A converters ● THD+N: < 0.003 % @ 1 kHz ● Crosstalk attenuation: > 100 dB @ 1 kHz ● S/N ratio (weighted): > 80 dB
Sample Rates (Digital/Analog)	32, 48, 96, 192 kHz

Audio-over-IP Input/Output

Standards	RAVENNA, AES67, SMPTE ST2110-30/-31, Axia Livewire+™, Dante® in AES67 mode
Supported Formats	L24, L16, AM824
Number of Channels	Up to 64 per Stream
Sample Rates	32, 48, 96, 192 kHz
Discovery	mDNS, SAP, Manual Configuration
Channel assignment by internal crossbar	
Seamless Protection Switching (according to SMPTE ST2022-7)	

Ancillary Data Output

Hardware	<ul style="list-style-type: none"> ● 8x RS232 Outputs, on 1x SUB-D 26 ○ Breakout cable (SUB-D 26 -> 8x SUB-D 9)
UDP	<ul style="list-style-type: none"> ● 16x UECP-over-UDP outputs (according to UECP v7.1)
Other formats on request	

Encoding Algorithms (Decoding)

<ul style="list-style-type: none"> ● MPEG-1/2 Layer 2 (according to ISO 11172-3, ISO 13818-3) ● MPEG-1/2 Layer 3 (according to ISO 11172-3, ISO 13818-3) ● AAC-LC, HE-AACv1, HE-AACv2, AAC-LD, AAC-ELD (ADTS and LOAS framing, according to ISO 13818-7, ISO 14496-3) ● xHE-AAC® (according to ISO 23003-3, ISO 14496-3/Amd 3) ● AC-3/E-AC-3 (according to ATSC A/52) ● Opus ● G.711 μ-Law/A-Law, G.722 ● MicroMPX® ● Others on request 	<ul style="list-style-type: none"> ● Stereo, Joint Stereo ● Mono (Extract/Mixdown) ● 5.0/5.1 ● 7.0/7.1
Audio Channel Configurations (dependant on algorithm)	
Embedded Metadata	<ul style="list-style-type: none"> ● RDS/UECP for DVB ● ID3 Tags for Internet Radio Streaming

Network Interfaces

4x Ethernet interfaces (IEEE 802.3, RJ-45, 10/100/1000 Mbps)
Isolation of all networks by integrated firewall
Roles can be freely assigned to any of the interfaces (Management, Data, etc.)

Q9X-R DVB-S2 Satellite Receiver

Specifications (continued)

System Configuration, Control and Monitoring

HTML5 Web UI

- Remote Control
- REST API
 - EmBER+
 - NMOS IS-04/IS-05
 - SNMPv2c

- User Management
- Fine-grained permission control
 - LDAP(S) authentication

Power Requirements

- Connectors
- 1x IEC60320 C14
 - 1x IEC60320 C14 (for 2nd power supply 100-230 V AC)
 - 1x Neutrik powerCON (for 2nd power supply -48 V DC)

- Power Supply
- 100 to 240 V AC +/- 10%, 50 to 60 Hz
 - -48 V DC
 - Redundant Power Supply

Power Consumption < 20 W

Physical Parameters

Chassis 19", 1 RU

Size (W/D/H) 483 mm / 365 mm / 44 mm

Weight 6 kg

Environmental Conditions

Operating Temperature 0 to 45 °C

Storage Temperature -20 to 70 °C

Humidity < 95 % (non-condensing)

Legend: ● Default ○ Optional

Ordering Options

Article Number	Name	Description
25020007	Q9X-R DVB-S2 Satellite Receiver Basic	Satellite Receiver for up to 4 analog or digital channels
25020008	Q9X-R DVB-S2 Satellite Receiver High-Performance	Satellite Receiver for up to 4 analog or 12 digital channels
25020009	Q9X-R DVB-S2 Satellite Receiver Basic (VLSR)	Satellite Receiver for up to 4 analog or digital channels, with Very Low Symbol Rate Tuner
25020010	Q9X-R DVB-S2 Satellite Receiver High-Performance (VLSR)	Satellite Receiver for up to 4 analog or 12 digital channels, with Very Low Symbol Rate Tuner

Hardware Options

Article Number	Name	Description
25030002	Q9X - Redundant Power Supply (230V)	Adds a second 230V power supply for redundancy
25030005	Q9X-R - Extension Board 4A4D	Adds another 4 analog/digital output channels (only for High-Performance variants)
25030010	Q9X-R - Internal Storage 1TB	Adds a 1TB internal storage for backup files and recordings

Software Options

Article Number	Name	Description
25040002	Q9X-R - Channel License	This software option unlocks a single decoder channel. Up to 4 channels may be licensed on a Basic device, up to 16 channels may be licensed on a High-Performance device.
25040004	Q9X-R - RAVENNA/AES67/Livewire	Unlock Audio-over-IP outputs as per RAVENNA/AES67/Livewire.
25040005	Q9X-R - SRT/RIST I/O	Unlock SRT and RIST Input/Output.
25040003	Q9X-R - ASI Output	Unlock the ability to output the received transport stream via ASI.
25040009	Q9X-R - IP Output	Unlock the ability to output the received transport stream via IP.
25040008	Q9X-R - File Backup	Unlock the ability to play a local file as a failsafe in case of an input error.